



Design & Simulation of Wearable UWB Antenna for Body Area Network

Priyanka¹, Er. Ankur Singhal²

¹M. Tech. Student, (ECE) GIMT, Kurukshetra Haryana, INDIA

²Assistant Professor GIMT, Kurukshetra Haryana, INDIA

Abstract: A microstrip patch antenna is presented for wide band application. The proposed antenna is used to air bone radar system. The proposed antenna consists of a octagonal radiating patch and a partial ground plane. The substrate of the proposed antenna is made of Dacron fabric with permittivity 3. The ground plane is slotted with author name initials. Super wide bandwidth is achieved by optimizing the geometry, introducing a square slot in the partial ground plane and introducing novel slot pattern on the radiating patch of the antenna. In this article, slotted wireless icon is used. The dimension of the proposed antenna substrate is $40 \times 34 \times 1.7 \text{ mm}^3$ and the bandwidth 10.969 GHz starting from 38.965 GHz to 49.9333 GHz for return loss less than -10 dB. The gain variation is from 3.2 dB to 11.2147 dB and average total efficiency more than 83%. Maximum power of 19.39mW may be set as input to the proposed antenna in order to guarantee compliance with the IEEE C95.1-1999 safety standard. The proposed antenna design details and simulated results are presented by HFSS.

Keywords: HFSS, SWB, Air Bone Radar System, Return Loss, Gain

I. Introduction

SWB is a radio technology, used for short-range communication. It occupies a bandwidth of at least 25% of the center frequency or more than 1.5 GHz unlike the narrower frequency band of the conventional systems. SWB signal uses Orthogonal Frequency Division Multiplexing (OFDM) as the modulation technique to occupy the wide frequency band. The commercial use of frequency bands from 3.1 to 14.6 GHz for SWB systems was approved by the Federal Communications Commission (FCC) in 2002 [2]. SWB offers extremely low radiated power in low/medium data-rate applications based on narrow pulses, thus being very attractive for air bone radar system.

Numerous papers have been published about the design, fabrication and applications of radar antennas and systems.

Previously reported works are based on single frequency band radar antennas [3] and later dual frequency band radar antennas [4]. Many of SWB antennas using rigid substrate material [5-6], large in size and small bandwidth [7-10][12-13] have been reported. However, it is quite difficult to obtain large bandwidth with compact size and a very low thickness in case of air bone antenna system. In this paper, a novel and compact design of SWB antenna is proposed for WBAN applications by merging the SWB technology with radar technology.

This paper is motivated from the above reported papers and presents a novel design of a wearable Octagonal SWB textile antenna. Novelty of this work is the slotted area of hexagonal patch that

represents the “wireless antenna” icon which is unique and also compact in size. The bandwidth of the proposed antenna operates in the wide range, achieving the SWB system requirements.

The rest of the paper is organized as follows. Section II outlines the complete design of SWB patch antenna. Measured and simulated results of the proposed antenna are discussed in Section III & IV. The conclusions are given in Section VI.

II. Octagonal patch Antenna Design

An Dacron substrate with 4.4 and thickness 1.7 mm was used in this design. The dimensions of the patch antenna were chosen in such way that when octagon radiate energy.

A patch of area 30×30 mm was selected. Such a patch resonated at 42.04 GHz in normal operating mode. To reduce the resonant frequency of the patch antenna, zero iteration was etched out from its radiating patch at its center. After that it is compare with second iteration which was etched out from its radiating patch as in star form.

In the design of the zero iteration patch, the dimension of the star length was varied and the antenna was tuned to resonate at 42.04 GHz using the commercial software HFSS. The final design obtained is shown in Fig. 1. The length of each side was 11.078 mm. The feed line width was 13.49 mm, which gives a characteristic impedance of 50Ω . The top view of octagonal patch antenna is as shown in the fig 1.

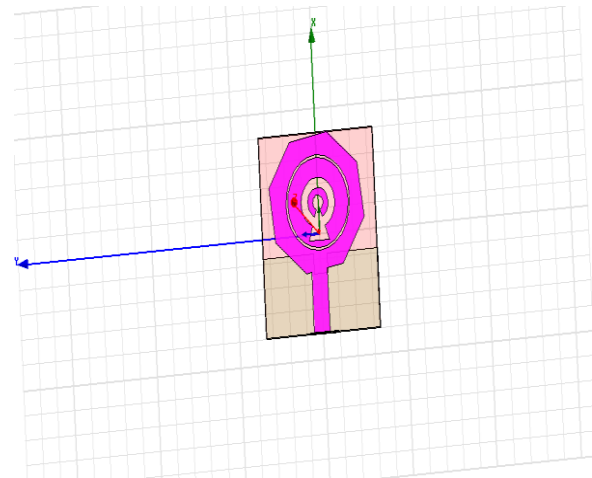

Fig 1. Top View of Octagonal Patch Antenna

The proposed antenna is compare with ground slotted patch antenna as shown in fig 2. Dimension of ground is 16×34 mm. A square notch is cut into the ground surface. This notch enhances the gain & minimizes the return loss.

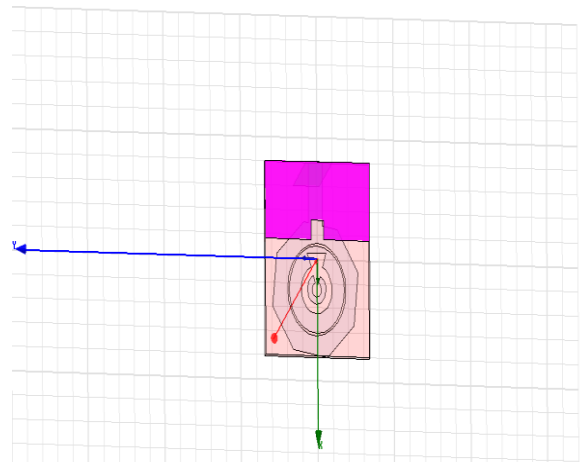

Fig 2. Bottom View of Octagonal Patch Antenna

Return Loss is important parameter for an antenna design. The ideal return loss is assumed to be -10db. Return loss should be minimum. The antenna is simulated in HFSS tool and return loss is measure. In case of octagonal patch antenna return loss is -15.0988 db. The return loss of octagonal patch is given by fig 3. This graphs shows that impedance matching of port to the antenna

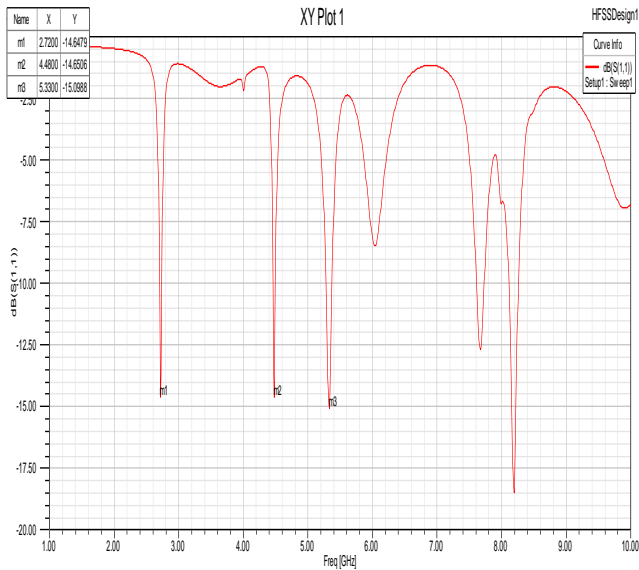

Fig 3. Return Loss of Octagonal Patch Antenna

The current distribution gives an idea to distribute a charge to the whole surface. The distributed current is given in ampere per meter. In case of zero iteration current distribution is given as $3.1871 \times e^{+001}$ ampere per m^2 . Current distribution of Octagonal patch is shown in fig 4.

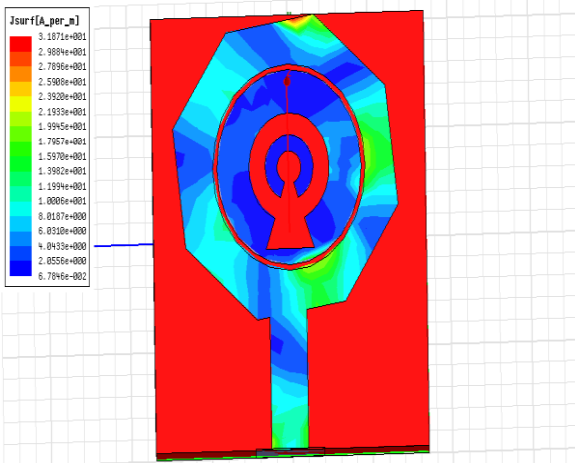

Fig 4. Current Distribution of Octagonal Patch Antenna

Gain is also an important parameter to design an antenna. The Gain enhanced by drawing different slots. Radiation pattern of gain given in fig 5. Gain of zeroth iteration antenna is 1.2841db

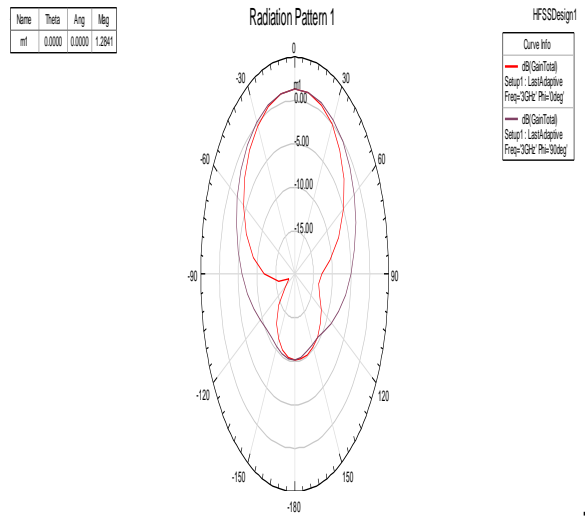

Fig 5. Radiation Pattern of Gain of Octagonal Patch Antenna

III. Octagonal patch Antenna with grounds lot Design

The author's name initial slotted antenna is compare with simple octagonal patch antenna as shown in fig 6. Same shape as previous antenna is designed. Two slots also designed to with ground area having dimension 4×4 mm. The name initial are A and S respectively

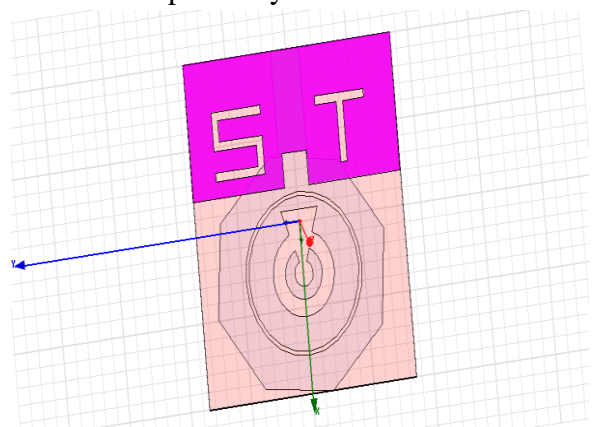

Fig 6. Top View of Octagonal Patch Antenna with Ground Slot.

In case of slotted antenna, return loss is -32.711 db. The return loss of slotted antennais given by fig 7. This graphs shows that return loss becomes

more negative as compared to simple octagonal antenna.

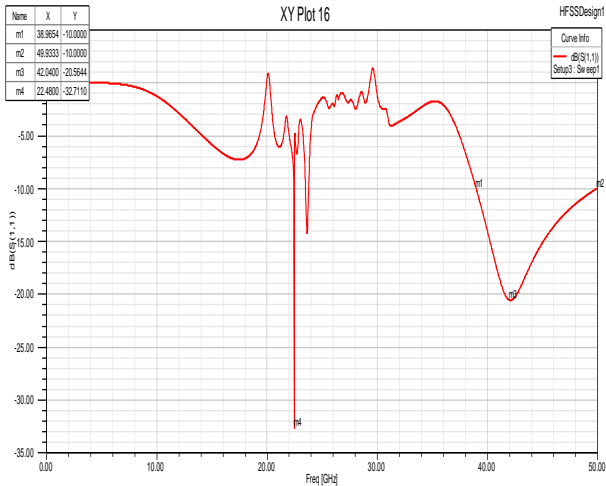

Fig 7. Return Loss of Octagonal Patch Antenna with Ground Slot Antenna

The current distribution is improved in slotted antenna. The distributed current is given in ampere per meter. In case of slotted antenna current distribution is given as $3.2844e^{+001}$ ampere per m^2 and $3.187 e^{+001}$ ampere per m^2 respectively. Current distribution on patch and slotted ground is shown in fig 8 and fig 9 respectively.

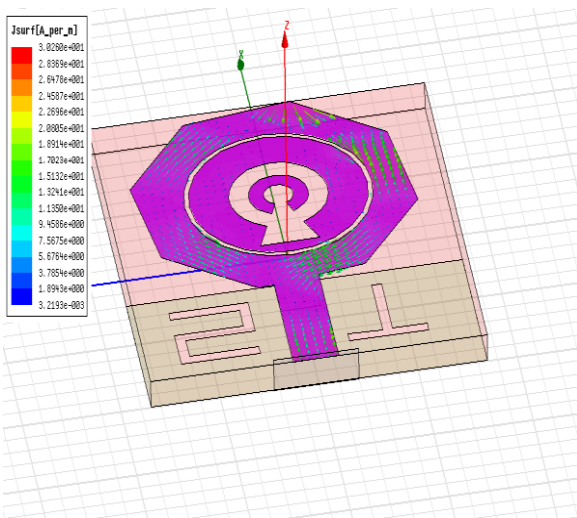

Fig 8. Current Distribution of Octagonal Patch Antenna with Ground Slot Antenna on Patch

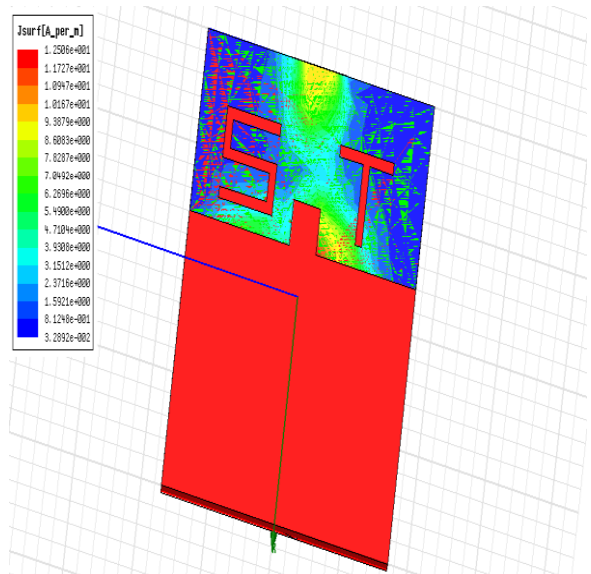

Fig 9. Current Distribution of Octagonal Patch Antenna with Ground Slot Antenna on ground.

Gain is improved with designing name initial slots. Radiation pattern of gain given in fig 10. Gain of slotted antenna is 11.2147 db.

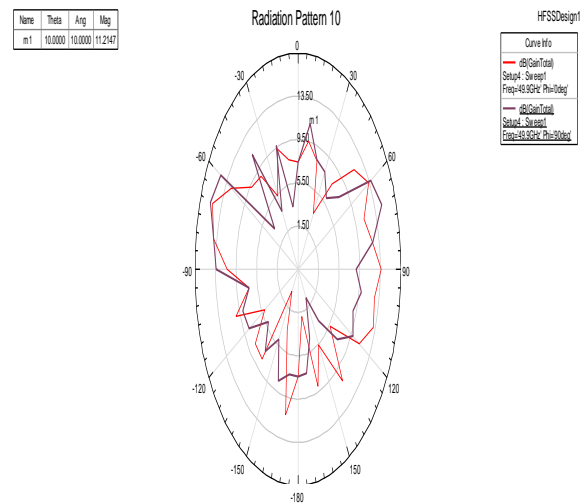

Fig 9. Radiation Pattern of Gain of First Iteration Antenna

IV. Comparative Analysis

In this section, comparative of two configurations is shown in tabular form. Return loss and bandwidth is compared in table 1.



Table 1. Comparative analysis of different iteration of Antenna

Sr. No	Parameter	Simple octagonal Patch Antenna	Simple octagonal Patch Antenna with initial slots
1.	F_L	14.9	13.05
2.	F_H	19.67	23.52
3.	F_0	17.45	17.45
4.	% B.W	27.33	60
5.	Return Loss	-15.0988	-32.711
6.	Gain	1.2841	11.2147

V. Conclusion

After Simulation, it is found that Octagonal patch antenna has low return loss with high gain and bandwidth. Simulated return loss is -32.711 with gain 11.2147 db and bandwidth 60% is obtained from slotted patch antenna. This range of frequency is used in air bone radar system.

References

1. T. Zasowski, F. Althaus, M. Stäger, A. Wittneben, and G. Tröster, "UWB for noninvasive wireless body area networks: Channel measurements and results," presented at the IEEE Ultra Wideband Syst. Technol. Conf. (UWBST 2003), Reston, VA, Nov. 2003.
2. First Report and Order, "Revision of part 15 of the commission's rule regarding ultra-wideband transmission system FCC 02-48", Federal Communications Commission, 2002.
3. G. A. Conway and William G. Scanlon, "Antennas for over-body surface communication at 2.45GHz," IEEE Transactions on Antennas and Propagation, vol. 57, no. 4, pp. 844-855, April 2009.
4. S. Zhu and R. J. Langley, "Dual-Band Wearable Textile Antennas on An EBG Substrate," IEEE Transactions on Antennas and Propagation, Vol.57, No.4, Apr 2009.
5. Mai A. R. Osman, "The Investigation of Flannel Fabric Layers", 2010 International Symposium on Antennas and Propagations, Macao, China, 23-26 November 2010.
6. Y. Chen, S. Yang, S. He, and Z.-P. Nie, "Design and analysis of wide and planar monopole antennas using the multilevel fast multipole algorithm," Progress In Electromagnetics Research B, Vol. 15, 95-112, 2009.
7. Shuvashis Dey, Nandita Saha and Subrata Biswas. "Design and performance analysis of UWB circular disc monopole textile antenna and bending consequences." The 5th European Conference on Antenna and Propagation, 2011, April 2011, Rome, Italy.
8. Mahmud MS, Jabri FJJ, Mahjabeen B. "Compact UWB Wearable antenna on leather material for wireless applications," IEEE Antennas and Propagation Society International Symposium (APSURSI). Orlando, FL; July 2013.
9. M. Klemm and G. Troester, "Textile UWB antennas for wireless bodyarea networks," IEEE Trans. Antennas Propag., Vol. 54, no. 11, pp.3192-3197, Nov. 2006.
10. Chahat N., "Design and Characterization of an UWB Wearable Antenna", 2010 Lough borough Antennas and Propagation Conference(LAPC), 2010, pp. 461-464.



11. Ray, K. P., Tiwary, S. "Ultra Wide Band Printed Hexagonal Monopole Antennas", IET Microwaves, Antennas and Propagation, 2010, vol. 4,no. 4, p. 437-445.
12. Mondal T, Das S. "UWB printed hexagonal monopole antennas with WLAN band rejection," IEEE Antenna Week (IAW). Kolkata, India; 2011.
13. Lodi, G. A., R. I. Zafar, and M. Bilal. "A novel goblet shaped patch antenna for ultra wide band applications." *Communication Technology (ICCT), 2010 12th IEEE International Conference on*. IEEE, 2010.
14. "IEEE standard for safety levels with respect to human exposure to radiofrequency electromagnetic fields, 3 kHz to 300 GHz," IEEE Standard C95.1 (1999).
15. FCC report and order for part 15 acceptance of ultra wideband(UWB) systems from 3.1–10.6 GHz, Washington, DC, 2002.
16. Kahrizi, M., T. Sarkar, and Z. Maricevic, "Analysis of a wide radiating slot in the ground plane of a microstrip line," *IEEE Trans. Microwave Theory Tech.*, Vol. 41, 29–37, January 1993.
17. Chair, R., A. A. Kishk, and K. F. Lee, "Ultrawide-band coplanar Waveguide-fed rectangular slot antenna," *IEEE Antennas and Wireless Propagation Lett.*, Vol. 3, 227–229, 2004.
18. Sze, J. and K. Wong, "Bandwidth enhancement of a micro stripline-fed printed wide-slot antenna," *IEEE Trans. Antennas and Propagation*, Vol. 49, 1020–1024, July 2001.
19. Sharma, S. K., L. Shafai, and N. Jacob, "Investigation of wide band microstrip slot antenna," *IEEE Trans. Antenna and Propagation*, Vol. 52, No. 3, 865–872, March 2004.
20. Latif, S. I., L. Shafai, and S. K. Sharma, "Bandwidth enhancement and size reduction of microstrip slot antenna," *IEEE Trans. Antenna and Propagation*, Vol. 53, No. 3, 994–1003, March 2005.
21. Behdad, N. and K. Sarabnadi, "A multi resonant single element wideband slot antenna," *IEEE Antennas and Wireless Propagation Lett.*, Vol. 3, 5–8, 2004.
22. Behdad, N. and K. Sarabandi, "A wide-band slot antenna design employing a fictitious short circuit concept," *IEEE Trans. Antennas and Propagation*, Vol. 53, 475–482, January 2005. HFSS 13 Software, Ansoft Corporation.